

VALVULAS CENTRAL HIDRÁULICA

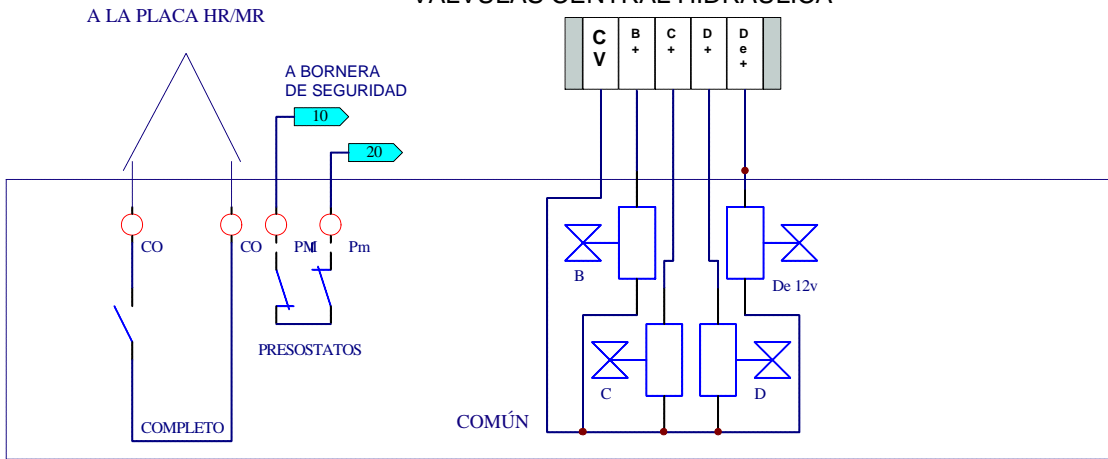

SEGURIDADES 110VCA

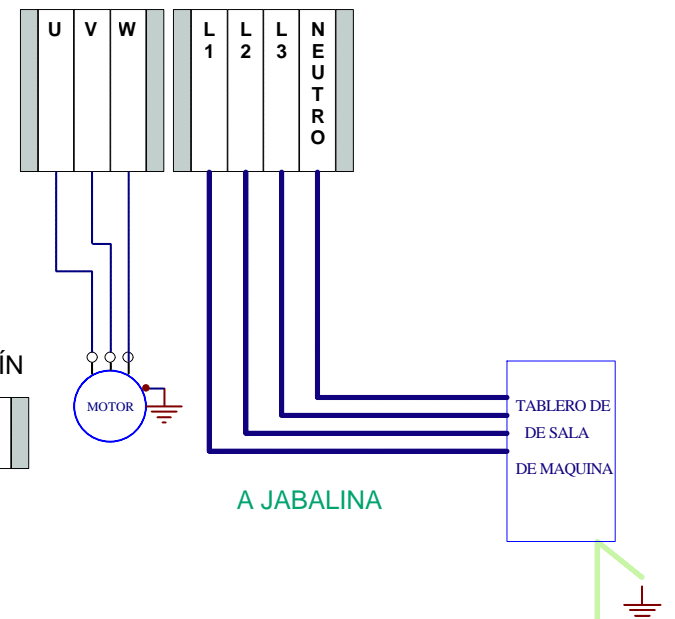
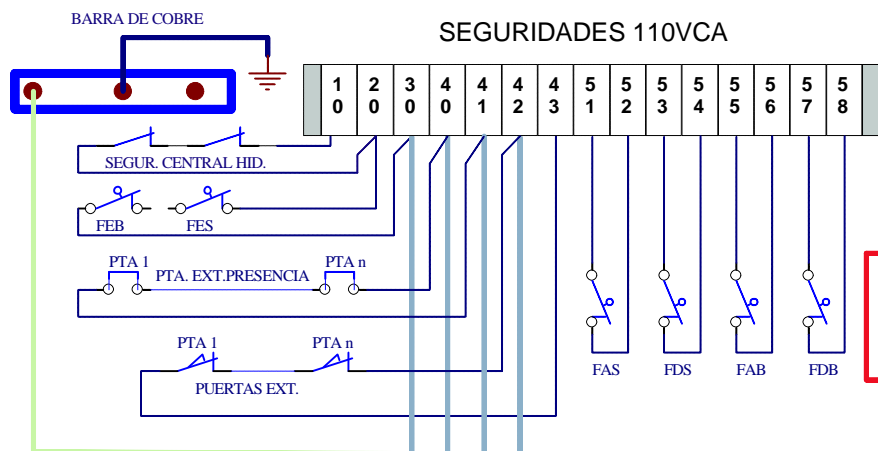

EN CAJA INSPECCIÓN

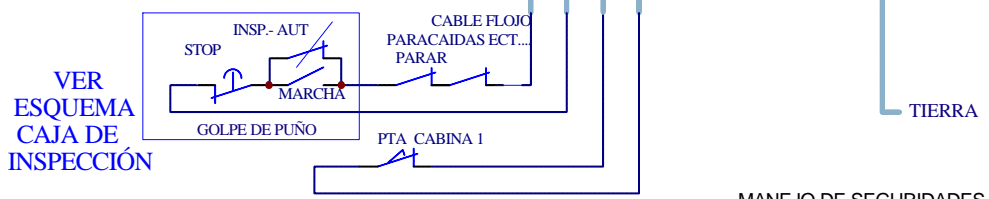

VER ESQUEMA CAJA DE INSPECCIÓN

INGENIERÍA WILCOX	
TAMANO: A4	ESQUEMA SEGURIDADES 380V PM BLAIN
FECHA:	22 DE ENERO DE 2007 PLANO N° 53 DE